

upright profile belt housing

Minimum swath 48"
Maximum swath 120"

| IFA swath | under 85" | over 84" |
|----------------------|------------------------------------|------------------------------------|
| belt housing height | 30 ⁷ / ₈ in. | 33 ¹ / ₈ in. |
| flail housing height | 20 ³ / ₄ in. | 21 ³ / ₄ in. |

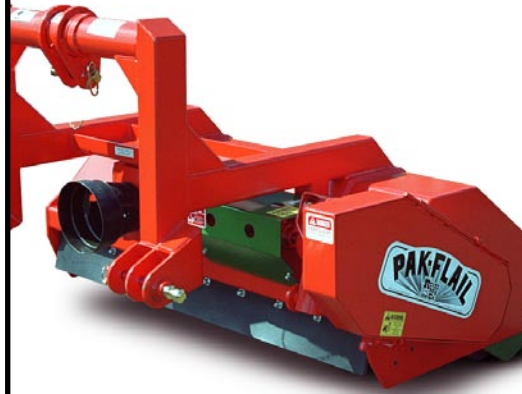

vineyard profile belt housing

Minimum swath 48"
Maximum swath 120"

| IFA swath | under 85" | over 84" |
|----------------------|------------------------------------|------------------------------------|
| belt housing height | 23 ¹ / ₄ in. | 23 ¹ / ₄ in. |
| flail housing height | 20 ³ / ₄ in. | 21 ³ / ₄ in. |



low profile belt housing

Minimum swath 74"
Maximum swath 120"

| IFA swath | under 85" | over 84" |
|----------------------|------------------------------------|------------------------------------|
| belt housing height | 25 ⁷ / ₈ in. | 24 ³ / ₄ in. |
| flail housing height | 20 ³ / ₄ in. | 21 ³ / ₄ in. |

specifications

Flail housing 1/4" steel plate formed housing.

Rotor shaft 1 15/16" diameter rotor shaft

Rotor bearings 1 15/16" double row spherical roller bearings

Cut height 0"- 5" adjustable cut height

Belt drive 4 groove 5V Powerband®



Rears quick-draw tensioner

pull drive belts to their proper tension-
spring indicator registers target tension



Flail gearbox 1:3 ratio, 85hp rating

Input driveline category 4

Flail weight 84"unit, upright belt housing, FL920 or FL960 blades: 1400lbs.

Roller construction 1 3/4" dia. roller shaft in 6 5/8" dia. roller

Roller bearing Triple seal ball bearing with eccentric locking collar

Hydraulic pantograph option up to 24" of travel

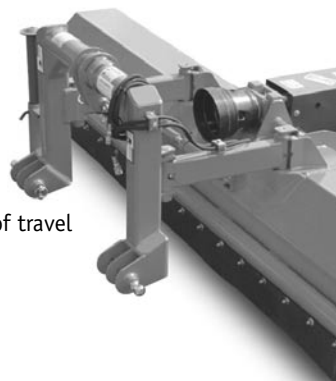

blades



FL920A

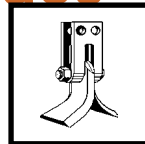

FL930C

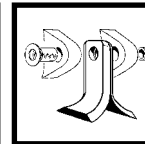

FL940HB

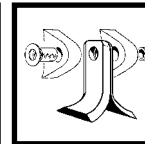

FL946HB

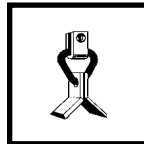

FL960A

Part N°

FL920 Grass blade

FL930 Reversible knife

FL940 Reversible knife

FL946 Hardfaced FL940

FL960 Reversible knife

Application

Mowing

Course mowing and shredding

Course mowing and shredding

Course mowing and shredding

Mowing and light shredding

narrow

Designed for applications with width constraints, the **narrow IFA** is 10" narrower than a standard IFA with the same swath.

Available with upright belt housing or vineyard belt housing.

Available with FL940 or FL946 blades, *above*.

**For more information,
or the location of your nearest dealer,
please call 800.547.8925**

